



# Centrifuge P 100

Solid-jacket Centrifuge for the Separation of Solids from Liquids



Centrifuge P 100



Centrifuge P 100 integrated in a complete cleaning system

Technical Data	
continuous liquid throughput	max. 100 l/min. water/emulsion
rotor capacity	12 dm <sup>3</sup>
solids capacity	5 dm <sup>3</sup>
rotor speed	3000 rpm
separating factor	1.550 g (g = gravity acceleration)
drive	direct drive with frequency converter
drive power	3 kW
solids discharge	automatically
liquid return	under pressure
inlet tank	-
clean liquid tank	-
remarks/ other	compact system

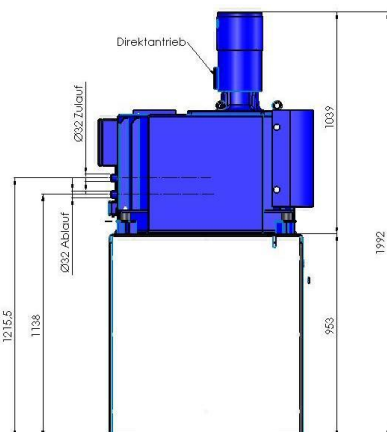

Side view

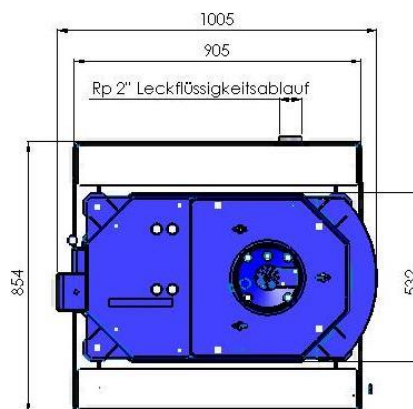

View from above



Turbo-HKS GmbH  
 Robert-Gerwig-Strasse 25  
 78244 Gottmadingen  
 Germany  
 +49 (0) 7731 / 8801-0  
 +49 (0) 7731 / 8801-18  
 www.turbo-hks.com  
 info@turbo-hks.com